

ROCKHAMPTON ALTERNATE INTERNATIONAL AIRPORT (AUSTRALIA)

AERODROME OBSTACLE CHART - ICAO

TYPE A (OPERATING LIMITATIONS)

To be read in conjunction with current NOTAM

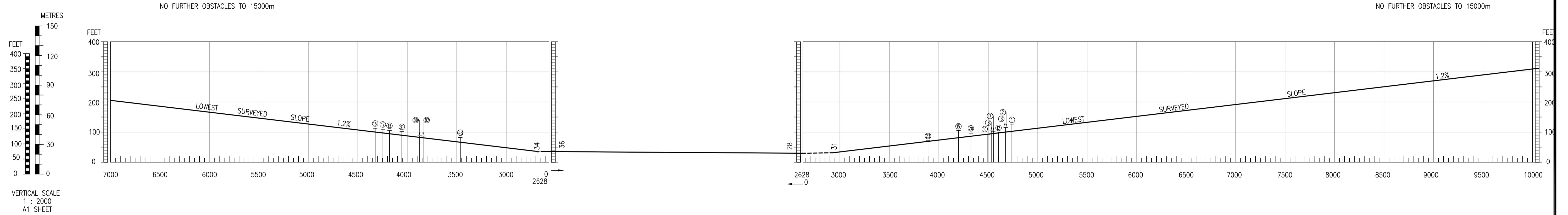

RWY 15-33 OPERATIONAL DATA		
RWY 15	DECLARED DISTANCES	RWY 33
2628	TAKE-OFF RUN AVAILABLE (TORA)	2568
2928	TAKE-OFF DISTANCE AVAILABLE (TODA)	2688
2628	ACCELERATE-STOP DISTANCE AVAILABLE (ASDA)	2568
2568	LANDING DISTANCE AVAILABLE (LDA)	2568

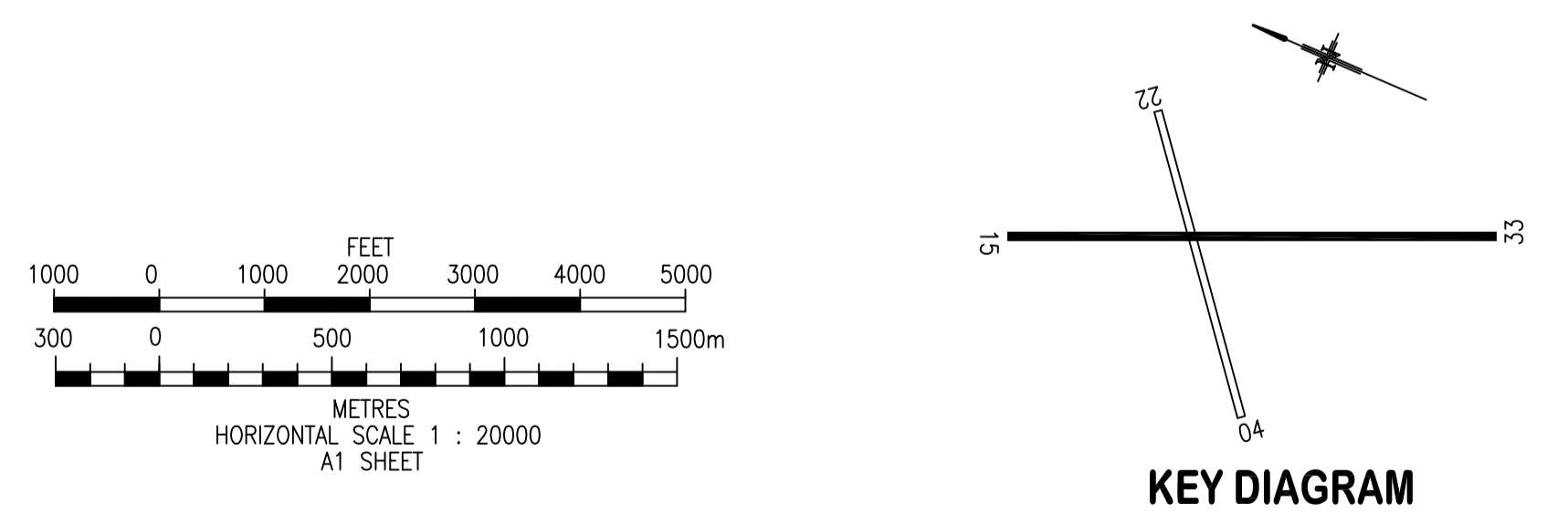
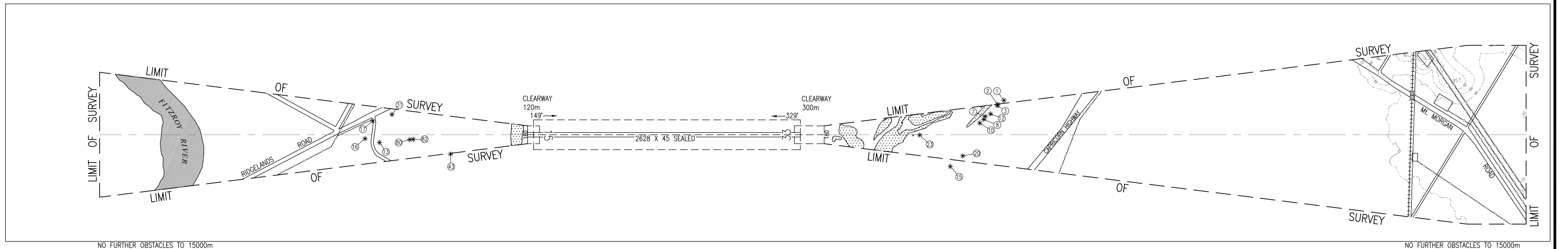

CONTOUR HEIGHTS SHOWN ARE IN FEET.
AND ARE ACCURATE WITHIN 8 FEET.

LEGEND	
Identification Number	①
Tree(s) or Shrub(s)	*
Transmission Line or Overhead Cable	—
Prominent Transmission Line	—
Spot Elevation (accuracy within 8ft)	95±
Railway	+++++
Terrain Penetrating Lowest Surveyed Slope	—
Lake (non-perennial)	—
Large River (perennial)	—

ORIGINALLY PRODUCED BY THE ROCKHAMPTON CITY COUNCIL WORKS SERVICES UNIT.
THIS AMENDMENT SURVEYED BY AERODROME OPERATION SUPPORT PTY LTD DECEMBER 2012.
NOTE: 1. DATUM FOR LEVELS IS AUSTRALIAN HEIGHT DATUM (AHD).
2. SURVEY ACCURACY IS TO FOURTH ORDER.
3. GRADIENTS TO OBSTACLES LESS THAN 1.18% ARE NOT SHOWN.
4. GRADIENTS TO ALL OBSTACLES WITHIN THE TAKE-OFF SURFACES ARE LESS THAN 1.6%
5. DATA FOR ALL OBSTACLE GRADIENTS IS INCLUDED IN THE TYPE A "LISTING OF OBJECTS" - SEPTEMBER 2013
Acad File : a0001701g

Surveyed	R.D.	Feb 2000
Drawn	I.L.	Mar 2000
Designed	I.L.	Mar 2000
Checked		



ROCKHAMPTON REGIONAL COUNCIL
APPROVED: *[Signature]* DATE: SEPTEMBER 2013

DESCRIPTION	DATE
I.L. 15 TKOF - TREE 12 HEIGHT REVISED	SEP. 2013
I.L. 33 TKOF - TREES 9, 10, & 54 REMOVED	SEP. 2013
M.T. 15 TKOF - TREE 23 ADDED	AUG. 2012
M.T. 33 TKOF - TREE 19 REMOVED	AUG. 2012
I.L. 15 TKOF - TREE 4 REMOVED, TREE 20 ADDED.	MAR. 2010
I.L. 33 TKOF - TREES 31, 35, 40, 44, 48, 55 & 90 REMOVED.	MAR. 2010
I.L. 33 TKOF - TREES 9, 10, 13, 16, 17 & 19 ADDED.	MAR. 2010
I.L. LOGO REVISED	NOV. 2008
I.L. TREE HEIGHTS AND GRADIENTS REVISED	DEC. 2006
I.L. 15 TKOF - TREE 9 REMOVED, TREE 15 ADDED.	30/10/03
I.L. 33 TKOF - TREES 30, 32, 42, 47, 53 & 58 REMOVED.	30/10/03
I.L. 33 TKOF - TREES 35 & 90 ADDED.	30/10/03
ORIGINAL ISSUE	10/3/2000

DRAWN: AMENDMENT RECORD PASSED: DATE: